

Experimental investigation on the effect of the switching frequency on the performance of a thermal wave adsorption heat pump

MOSTAFA GAD EL-RAB^{1,2}, MAHMOUD KHALED^{1,a}, BELAL DAWOUD³ AND EMAD AMER²

¹ Energy and Thermo-Fluids Group ETF, School of Engineering, Lebanese International University LIU, 146404 Mazraa, Beirut, Lebanon

² Mechanical Power Engineering Department, Faculty of Engineering, El-Menoufiya University, Shebin El-Kom, Egypt

³ R&D New Technologies, Viessmann Werke GmbH & Co KG, 35107 Allendorf/Eder, Germany

Received 30 May 2013, Accepted 11 August 2013

Abstract – In this paper, a two modular zeolite water adsorption heat pump (AHP) based on the thermal wave concept has been experimentally investigated. Each module composes of two heat exchangers contained in a hermetic stainless steel vessel. The first heat exchanger is the adsorber/desorber located on the top of the vessel, while the second is the evaporator/condenser heat exchanger located on the bottom of the vessel. Throughout this work, the effect of the non-dimensional switching frequency, which has been introduced and theoretically investigated by Alam et al. [Int. J. Heat Mass Transfer 43 (2000) 4419–4431], on COP and the mean heating power of an adsorption heat pump has been experimentally investigated under one typical working condition of AHPs. The results showed that the switching frequency and adsorber/desorber flow rate have strong influences on both COP and the mean heating power. It has been also found that there is an optimum switching frequency corresponding to each flow rate, at which the COP attains its maximum value. The obtained optimum switching frequencies vary slightly from 0.28 at an adsorber fluid flow rate of 0.6 l.min⁻¹ to 0.32 at 1 l.min⁻¹.

Key words: Adsorption / heat pump / zeolite-water / switching frequency / thermal wave

1 Introduction

In recent years, adsorption heat pump/refrigeration systems have drawn considerable attention due to their lower environmental impact since these systems use non ozone depleting working substances. Moreover, gas-fired adsorption heat pumps have a remarkable energy saving potential compared to gas-condensing boilers, which represents the state of the art of gas fired heating appliances. In this context, several advanced cycles have been proposed to achieve higher coefficient of performance (COP) values over single stage intermittent adsorption cycles. Meunier [2] as well as Douss and Meunier [3] have proposed and analyzed the solid adsorption cascading cycle in which they applied an active carbon-methanol pair topped by a zeolite water system. In this cascading cycle, traditional NaX and A type zeolites were applied at a desorption temperature as high as 300 °C. In a commercial gas-fired adsorption heat pump system, the realization of

this desorption temperature level has been proven to be unfeasible.

One of the technically promising regenerative adsorption heat pump cycles is the so called two-bed regenerative thermal wave cycle introduced by Tchernev and Emerson [4]. According to this cycle, the two adsorption beds are connected in series with the heat source and heating net heat exchangers. The heat recovery between the two adsorption beds is realized by reversing the flow direction of the bed heat transfer fluid at the end of each adsorption/desorption working phase. One of the main technical advantages of this cycle is the need to only one circulating pump for the bed heat transfer fluid loop. Moreover, this pump could be located close to the heating net heat exchanger, exhibiting the medium cycle temperature and the lowest temperature changes compared to the two circulating pumps required for the two heat transfer fluid loops of two bed direct heat recovery cycle. This leads to a remarkable cost saving and long time durability of the thermal wave heat pump. Amar et al. [5] as well as Haji and Worek [6] have performed a detailed

^a Corresponding author: mahmoud.khaled@liu.edu.lb

numerical modelling and simulation of the Tchernev thermal wave cycle. They have concluded that the cycle time is one of the key operating parameters of this regenerative cycle. An excessively short cycle time is responsible for lower cooling capacity and coefficient of performance (COP). On the other hand, a too long cycle time results in a quite high heating power on the cost of a too poor COP. The effect of switching speed on the two bed thermal wave cycle performance has been numerically studied by Zheng et al. [7,8]. They showed that there is an optimum switching speed to optimize COP and cooling capacity, which are different, for a given design and set of operating conditions. Alam et al. [1] have investigated numerically the influence of heat exchanger design parameters on the system performance as well as on the switching frequency defined previously by Zheng et al. [7,8] of a two-bed silica gel-water thermal wave cooling system. They showed that the optimum switching frequency is strongly dependent on the heat exchanger design parameters. They also showed that the COP and cooling capacity could not be optimized at a single switching frequency. Voyiatzis et al. [9] have also concluded that the performance of the chiller is very sensitive to the switching frequency.

The main objective of this work is to experimentally investigate the influence of the previously mentioned switching frequency on the performance of a two-modular zeolite-water thermal wave adsorption heat pump at different adsorber loop flow rates in order to define a suitable control strategy for predicting the optimum switching time, which gives the maximum COP and in the same time achieves the desired heating power.

The rest of this paper is organized as follows. Section 2 describes the two-modular thermal wave adsorption heat pump operational mode. In Section 3, the experimental methodology is presented. Section 4 deals with the results and discussion. Finally, Section 5 draws the main issues of the work.

2 Two-modular thermal wave adsorption heat pump

Figure 1 represents the flow diagram of the investigated adsorption heat pump. The core of the heat pump is the two modules. Each module is a vacuum tight cylindrical vessel containing two heat exchangers [10].

The heat exchanger on the top of each module is the adsorber/desorber, which is constructed as a finned-tube heat exchanger, with water as a heat transfer fluid flowing inside the tubes and zeolite-NaY loose pellets incorporated between the fins. A metal sieve is applied to prevent the pellets from falling out of the heat exchanger. On the bottom of each module the evaporator/condenser heat exchanger is located, which consists of two-layers of wavy tube spirals, each fixed on a suitable tray with brine applied as a heat transfer fluid. The whole module including the two heat exchangers is made of high grade stainless steel. Figure 1 presents an operation state, in which module 1 (M1) is working as a desorber/condenser

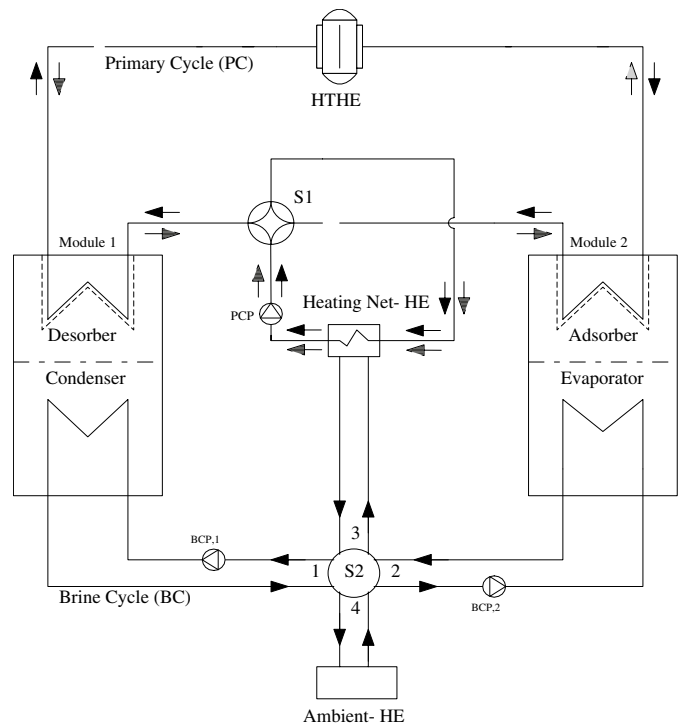

Fig. 1. Schematic diagram of the investigated two-modular adsorption heat pump.

and module 2 (M2) as an adsorber/evaporator. The adsorber and desorber are interconnected with the heating-net (HNHE) and the high temperature (HTHE) heat exchangers through a central switching unit (S1). This loop is termed as the primary cycle (PC) and is equipped with the circulating pump (PCP). The central switching unit S1 enables reversing the flow direction in the primary cycle by each 90° rotation of its rotor, and consequently, realizing the thermal wave heat recovery between the adsorber and desorber heat exchangers according to Tchernev and Emerson [4]. The evaporator and condenser heat exchangers are interconnected with the HNHE and the Ambient-heat exchangers via a second central switching unit (S2) with brine flowing in this loop (Brine Cycle (BC)). The condenser/evaporator heat exchangers in Modules 1 and 2 are equipped with brine circulation pumps BCP1 and BCP2, respectively. In Figure 1, the central switching unit S2 connects the condenser of M1 (Path 1) with the HNHE (Path 3) and, in the same time, the evaporator of M2 (Path 2) with the ambient-HE (Path 4). This explains the necessity to assign a brine circulation pump to each module.

Upon reaching a certain condition for switching the primary cycle (e.g. a certain half cycle time or a predefined exit temperature out of the desorber or adsorber is reached) the primary cycle flow direction is reversed by rotating the rotor of S1 by 90°. Both desorption and adsorption processes in the two modules could not be terminated immediately as the process is not of a digital nature. Contrary to that, it has been observed that the condenser is still capable to deliver heat to the HNHE and

the evaporator could still receive heat from the ambient-HE, if switching the brine cycle is delayed for a certain time after reversing the flow direction in the primary cycle. This time interval between reversing the direction of flow in the primary cycle and the beginning of switching the brine cycle is therefore termed as the delay time. After this delay time a direct heat recovery between condenser and evaporator heat exchangers is realized by connecting loops 1 and 2 through S2 for a certain time. This time is termed as the internal heat recovery time. Directly after that, the two loops 1 and 2 are isolated from each other and also from the HNHE and ambient-HE and short circuited in themselves to realize the pre-cooling of the evaporator heat exchanger of M1 (previously worked as a condenser) and the pre-heating of the condenser heat exchanger of M2 (previously worked as an evaporator). In the pre-heating/pre-cooling phase the evaporator (in M1) is continued to cool down by evaporating refrigerant and the condenser (in M2) is continued to heat up by condensing refrigerant. Since the evaporator heat-exchanger (previously worked as a condenser) is filled with refrigerant, its pre-cooling takes longer time than pre-heating of the empty condenser (previously worked as an evaporator). Accordingly, the state of the evaporator is decisive for the duration of the pre-heating/pre-cooling phase. After finishing this pre-heating/pre-cooling phase the evaporator of M1 is connected to the ambient-HE (Paths 1 to 4) and the condenser of M2 is connected to the HNHE (Paths 2 to 3) in S2, respectively and the process time starts, in which M1 works as an adsorber-evaporator and M2 as a desorber-condenser. This sequence of operation has been patented by Hocker et al. [11].

The non-dimensional switching frequency is defined according to Alam et al. [1] as the ratio between the heat capacity of the adsorbent bed or adsorbent heat exchanger and the heat capacity rate of the adsorber heat transfer fluid multiplied by the half cycle time (t_{hc}).

$$w = \frac{m_{ab}C_{ab}}{\dot{m}_f C_f} \frac{1}{t_{hc}} = \frac{\tau_{ab}}{t_{hc}} \quad (1)$$

where m_{ab} and C_{ab} represent the mass and heat capacity of adsorbent bed (zeolite) respectively, while \dot{m}_f and C_f are the mass flow rate and heat capacity of heat transfer fluid respectively. The first part of equation (1) represents an internal adsorption “bed” characteristic time (τ_{ab}), while t_{hc} is an external time and represents the half cycle time, which can be independently adjusted during the experiments. Multiplying both numerator and denominator of this first part by the difference between desorption and adsorption end temperatures indicates that τ_{ab} represents the ratio between the heat gained by the adsorbent bed and the rate of heat transferred to/from the bed heat transfer fluid. The heat transferred to/from the adsorbent bed depends mainly on the combined heat and mass transfer characteristics of the adsorbent bed as well as on the heat transfer characteristics of the condenser/evaporator heat exchangers. In an “ideal” adsorption heat pump design with no heat and mass transfer resistances and with infinite heat transfer areas, the

half cycle time should equal $m_{ab}C_{ab}/\dot{m}_f C_f$ and the corresponding “optimum” switching frequency must then equal one.

3 Experimental methodology

During the experiments, the investigated switching frequency has been adjusted by changing the process time while keeping the time of the remaining phases constant. The half cycle time is the sum of process time, delay time, internal heat recovery time, and pre-heating/pre-cooling time. In this set of experiments, boundary conditions have been adjusted to the following values: $T_{HNHE,ex} = 24$ °C, $T_{ev,in} = 5.8$ °C, $T_{HTHE,ex} = 140$ °C, delay time = 110 s, internal heat recovery time = 30 s, pre-heating/pre-cooling time = 350 s. The primary cycle heat transfer fluid flow rate has been adjusted to 0.6, 0.7, 0.8, 0.9, and 1 l.min⁻¹. To realize a wide range of switching frequencies, the process time has been varied between 800 and 1600 s. For the evaluation of the thermally driven heat pump process under investigation, the coefficient of performance (COP) is defined according to equation (2) as the ratio between the useful heat Q_{use} gained out of the HNHE and the input heat Q_{in} to the process in the HTHE.

$$COP = \frac{Q_{use}}{Q_{in}} = \frac{Q_{HNHE}}{Q_{HTHE}} = \frac{Q_{HN,PC} + Q_{HN,BC}}{Q_{HTHE}} \quad (2)$$

whereas the power input to the HTHE and obtained from the HNHE is defined by equations (3) and (4), respectively.

$$\dot{Q}_{HTHE} = \dot{m}_{PC} c_{PC} \Delta T_{HTHE} \quad (3)$$

$$\dot{Q}_{HNHE} = \dot{m}_{HN} c_{HN} \Delta T_{HNHE}. \quad (4)$$

The mean heating power (MHP) of the heat pump process is defined as the integral of the heating power obtained out of the HNHE as a result of the heat transfer from both primary and brine circuits within the heating net HE over the half cycle time divided by the half cycle time according to equation (5).

$$MHP = \frac{1}{t_{hc}} \int_0^{t_{hc}} \dot{Q}_{HNHE} dt. \quad (5)$$

Temperature measurements are carried out using Nickel-chrome, Nickel thermocouple pairs of class 1 having an absolute accuracy in measuring temperature difference of ± 0.1 K. The measurement of the mass flow rate of the primary cycle is accomplished with a mass flow meter with integrated density measurement. The operational principle is based on the Coriolis force and the mass dependence of the natural frequency of a swinging system. The mass flow meter works in the measuring range from 0 to 350 kg.h⁻¹ with a maximum error of $\pm 0.25\%$ of the respective measured value. A detailed uncertainty analysis showed a maximum relative error in COP measurements of $\pm 0.76\%$ from the measured value.

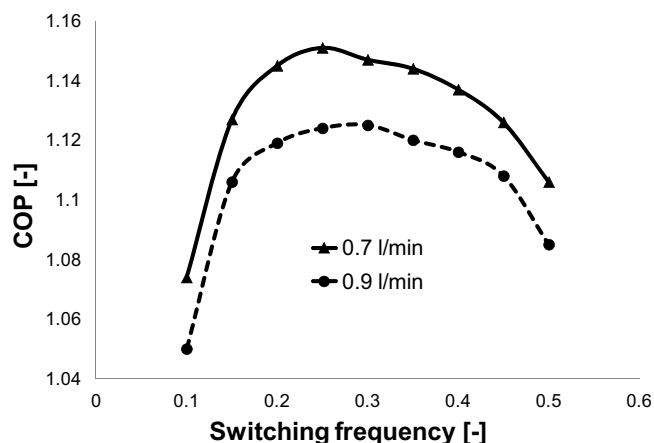

Fig. 2. Effect of switching frequency on the COP at two primary cycle flow rates.

4 Results and discussion

The effect of switching frequency on COP at two exemplary primary cycle flow rates is presented in Figure 2.

It could be observed that there is an optimum switching frequency for each PC-flow rate. Directly after switching from adsorption to desorption by reversing the primary cycle flow direction, there would be almost no temperature change over the HTHE or the HNHE, leading to the maximum degree of heat recovery between the two adsorption beds. On the same time, there is still no heat pump effect produced as the evaporator and condenser haven't started operation yet (low half cycle time and high ω -values). Accordingly, COP_{HP} would approach one ($COP_{HP} = 1 + COP_C$ and $COP_C \cong 0$ as the evaporator cooling effect approaches zero). In case the adsorption/desorption would continue for an infinite time (low ω -values), the result would be that the adsorber/desorber heat exchangers are completely cooled down to the adsorption-end temperature or heated up to the desorption-end temperature, respectively.

This implies that, in case of no thermal losses in the primary heat transfer fluid loop, the heat added in the HTHE required to heat up the heat transfer fluid from the adsorption-end to the desorption-end temperatures would be completely rejected in the HNHE, without producing any heat pump effect as the adsorbent beds have reached their equilibrium states. Accordingly, COP_{HP} would approach also the limiting value of one. Between those limiting durations of zero and infinity (high and zero ω -values, respectively), the heat pump COP_{HP} is expected to attain a maximum value, which should be higher than one. This is exactly, what Figure 2 is putting an evidence for. The value of the optimum switching frequency varies slightly from 0.27 to 0.3 as the PC-flow rate increases from 0.7 to 0.9 $l \cdot min^{-1}$. It is also evident from Figure 2 that increasing the primary cycle flow rate results in decreasing the COP. This is a special character of the thermal wave regenerative cycle, which is explained in accordance with Figure 3b.

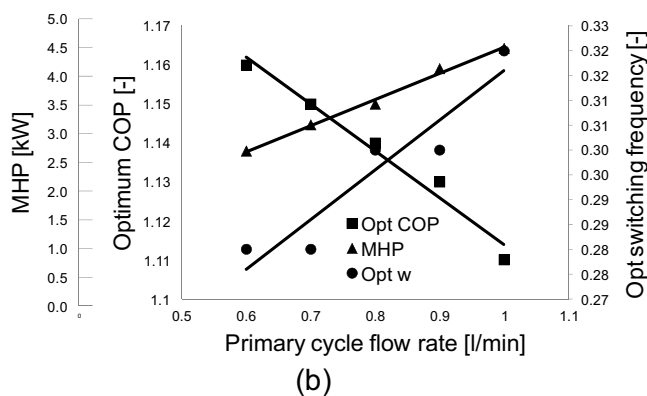
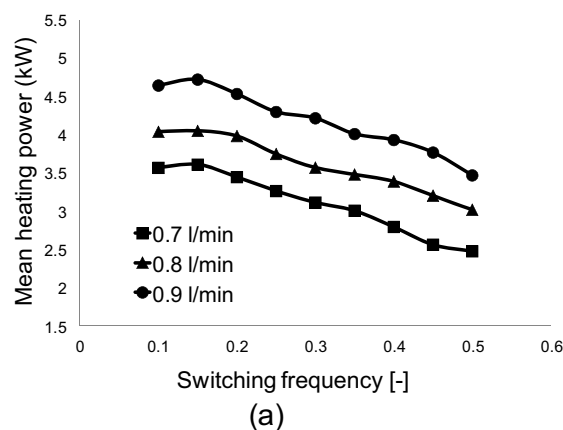

Fig. 3. (a) Effect of switching frequency on the MHP at different primary cycle flow rates and (b) Effect of primary cycle flow rate on the optimum switching frequency, optimum COP and the corresponding MHP.

The effect of ω on the mean heating power (MHP) at different primary cycle flow rates is illustrated in Figure 3a. At low ω -values (long half cycle time), the desorber exit temperature entering the HNHE increases steadily resulting in increasing the MHP. At higher adsorber flow rates the obtained MHP increases almost linearly for the same ω -value.

Figure 3b depicts the effect of the primary cycle flow rate on both optimum ω and COP values as well as on the MHP obtainable at the optimum switching frequency corresponding to that flow rate. It is evident that the optimum switching frequency increases slightly with increasing the PC-flow rate, which could be referred to the enhancement of the adsorber overall heat transfer coefficient. Accordingly, the required time for adsorption/desorption processes is decreased (the adsorption bed characteristic time τ_{ab} decreases) and the optimum switching frequency increases. In the same time, Figure 3b shows that increasing the PC-flow rate leads to a nearly linear decrease in COP within the studied range of PC-flow rate. In a first approximation, the COP of the thermal wave adsorption heat pump could be reduced to a multiplication of the COP of a vapour compression heat pump process working between the evaporator and condenser temperatures and the efficiency of a heat engine

formed by the components of the primary cycle. Increasing the adsorber flow rate means that the temperature differences over the adsorber and desorber heat exchangers will be decreased for a given amount of heat transferred. Consequently, the difference between the mean thermodynamic temperatures of the HTHE and the HNHE decreases leading to a reduction in the efficiency of the heat engine part of the cycle. This implies a reduction in the adsorption heat pump COP with increasing the adsorber flow rate and vice versa. Moreover, Figure 3b presents the effect of the PC-flow rate on the obtainable MHP at the corresponding ω_{opt} to each PC-flow rate. Linear correlations could then be defined for both MHP (dash-dot line) and ω_{opt} (dashed line) as functions of the PC-flow rate. Knowing the required MHP from the heat pump at a specific operating condition, the corresponding value of the adsorber flow rate could be obtained along with the optimum ω -value from such correlations. This leads to define the required half cycle time from equation (1) as τ_{ab} could then be estimated. Moreover, the optimum COP could be predicted from a similar correlation (solid line). Repeating this process for different operating conditions of the heat pump will result in defining a suitable control strategy, and moreover, offers a simple methodology to optimize the operation and, in the same time, predicts the COP of thermal wave adsorption heat pumps.

5 Conclusions

The effect of the adsorber flow rate and the switching frequency of the primary cycle of a two-modular zeolite/water thermal wave adsorption heat pump on the COP and the mean heating power at a typical working condition of adsorption heat pump in the middle European climate have been experimentally investigated. It could be observed that there is an optimum switching frequency at each adsorber flow rate, at which the COP attains a maximum. The optimum switching frequency increases with increasing the adsorber flow rate, which is referred to the enhancement of the adsorption bed heat transfer characteristics. The optimum COP increases with decreasing the adsorber flow rate, within the studied range of primary cycle flow rates. A simple control

strategy for this kind of adsorption heat pumps is described based on individual correlations for the optimum switching frequency, the optimum COP and the obtainable mean heating power as functions of the primary cycle flow rate.

References

- [1] K.C.A. Alam, B.B. Saha, Y.T. Kang, A. Akisawa, T. Kashiwagi, Heat exchanger design effect on the system performance of silica gel–water adsorption system, *Int. J. Heat Mass Transfer* 43 (2000) 4419–4431
- [2] F. Meunier, Theoretical performances of solid adsorbent cascading cycles using the zeolite-water and active carbon-methanol Paris: four case studies, *J. Heat Recovery Systems* 6 (1986) 491–498
- [3] N. Douss, F. Meunier, Experimental study of cascading adsorption cycles, *Chem. Eng. Sci.* 44 (1989) 225–235
- [4] D.I. Tchernev, D. Emerson, Closed Cycle Regenerative Heat Pump, 2nd International Workshop on Research Activities on Advanced Heat Pumps, Graz, 1988
- [5] N.B. Amar, L.M. Sun, F. Meunier, Numerical analysis of adsorptive temperature wave regenerative heat pump, *Appl. Thermal Eng.* 6 (1996) 405–418
- [6] A. Haji, W.M. Worek, Simulation of a regenerative closed-cycle adsorption cooling/heating system, *Energy* 16 (1991) 643–654
- [7] W. Zheng, W.M. Worek, G. Nowakowski, Performance optimization of two-bed closed cycle solid-adsorption heat pump systems, *Heat Mass Transfer* 31 (1995) 1–9
- [8] W. Zheng, W.M. Worek, G. Nowakowski, Effect of operating conditions on the performance of two-bed closed cycle solid-sorption heat pump systems, *ASME Trans. – J. Solar Eng. Eng.* 117 (1995) 181–186
- [9] E. Voyiatzis, A.J. Palyvos, N. Markatos, Heat-exchanger design and switching-frequency effects on the performance of a continuous type solar adsorption chiller, *Applied Energy* 85 (2008) 1237–1250
- [10] R. Lang, B. Dawoud, T. Miltkau, M. Stricker, A Sorption Heat Pump Module, European Patent, EP 1178269 B1, 2003, pp. 1–12
- [11] T. Hocker, R. Lang, F. Marth, U. Marx, R. Prescha, J. Wienen, B. Dawoud, R. Gasper, T. Miltkau, M. Stricker, A Method of Operating an Adsorption Heat Pump, European Patent, EP 1245910 B1, 2003, pp. 1–26